

# Modbus Protocol

for VASCO - Variable Speed Controller

VASCO Solar - Variable Speed Controller

and MIDA devices

# Index

1. Modbus introduction.....	3
2. Modbus on Nastec devices .....	3
3. Transmission modes.....	3
4. Connections.....	3
5. Programming.....	4
6. Index list.....	5
7. Definitions.....	14
8. Function codes .....	18

# 1. Modbus introduction

Modbus is a serial communication. Simple and robust, it has become a de-facto standard communication protocol, and it is now a commonly available means of connecting industrial electronic devices.

Modbus enables communication among many devices connected to the same network. Modbus is often used to connect a supervisory computer with a remote terminal unit (RTU) in supervisory control and data acquisition (SCADA) systems.

The development and update of Modbus protocols is managed by the Modbus Organization, an association of users and suppliers of Modbus compliant devices that seeks to drive the adoption and evolution of Modbus.

# 2. Modbus on Nastec devices

Modbus communication is performed on Nastec devices using RS485 Modbus serial port (if available).

Modbus communication is based on master-slaves configuration where the central unit (PLC, PC or BMS) acts as a master in the network and Nastec devices act as slaves. Master is thus able to monitor and program slaves sending or receiving messages based on Modbus protocol.

# 3. Transmission modes

Transmission mode used with Nastec devices has to be Modbus RTU.

In particular, it is possible to choose between four types of modes:

- RTU N81: 1 start bit, 8 data bits, 1 stop bit, No parity
- RTU N82: 1 start bit, 8 data bits, 2 stop bits, No parity
- RTU E81: 1 start bit, 8 data bits, 1 stop bit, Even parity
- RTU O81: 1 start bit, 8 data bits, 1 stop bit, Odd parity

# 4. Connections

	<p><b>Connections must be performed only by trained, skilled, and qualified personnel.</b></p> <p><b>Before performing any connection, disconnect the device from the main power supply and do not open it without having waited at least 5 minutes.</b></p> <p><b>After connections are performed, closed the device and tight all screws on the cover with washers before powering the device. Otherwise, there may be a failure to connect the cover to ground, creating the risk of electric shock or even death.</b></p>
---	---

# Single pump application

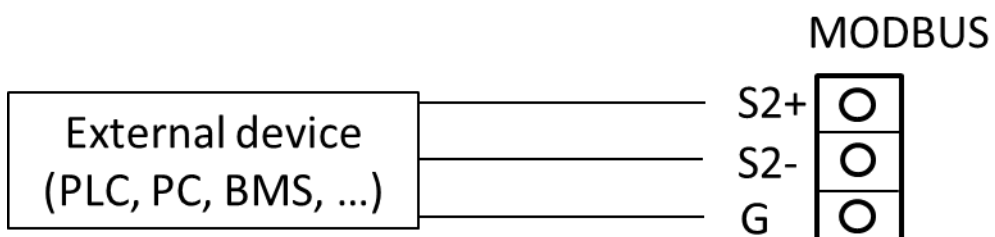

## Multi-pump application (COMBO mode)

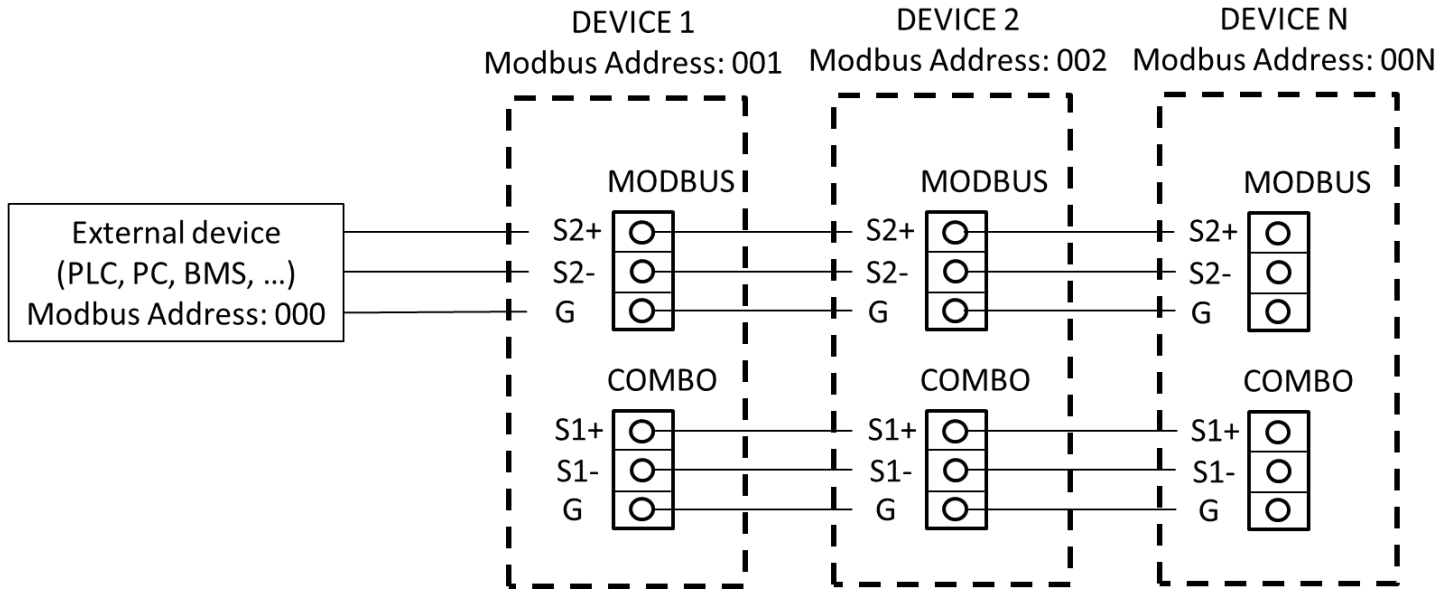

## 5. Programming

Access to “menu: connectivity” (default password 002) and set following parameters:

Parameters	Default	Description
MODBUS address XXX	1	MODBUS address from 1 to 247
MODBUS baudrate XXXXX	9600	MODBUS baudrate from 1200 bps to 57600 bps
MODBUS data format XXXXX	RTU N81	MODBUS data format: RTU N81, RTU N82, RTU E81, ETU O81

## 6. Index list

Modbus Index HEX	Modbus index DEC	Function	Menù category	Description	Range (DECIMAL)	Notes
33	51	03,06		Start / Stop of the inverter	0=OFF    1=ON	
34	52	03,06	Control	Set Value	[0 - 999,9] (unit)    0 - 9999 (in 1/10 steps)	Sensor range definition dependent
35	53	03,06	Control	Delta start	[0 - 999,9] (unit)    0 - 9999 (in 1/10 steps)	Sensor range definition dependent
36	54	03,06	IN / OUT	Full scale sensor	[0,1 - 999,9] (unit)    1 - 9999 (in 1/10 steps)	
37	55	03,06	Motor	Rated motor frequency	[0 - 500] Hz	
38	56	03,06	Control	Operating frequency	[F_min_motor - F_max_motor] Hz	Frequency range definition dependent
39	57	03,06	Motor	Rated motor voltage	[50 - 460] V	Inverter model dependent
3A	58	03,06	Motor	Voltage boost	[0 - 5,0] %    0 - 50 (in 1/10 steps)	
3B	59	03,06	Motor	Ramp up time	[1,0 - 300,0] sec    10 - 3000 (in 1/10 steps)	
3C	60	03,06	Motor	Ramp down time	[1,0 - 300,0] sec    10 - 3000 (in 1/10 steps)	
3D	61	03,06	Motor	PWM	1=2,5KHz    2=4KHz    3=6KHz 4=8KHz    5=10KHz	
3E	62	03,06	Motor	Ramp f min motor	[1,0 - 30,0] sec    10 - 300 (in 1/10 steps)	
3F	63	03,06	Control	Set Value 2	[0 - 999,9] (unit)    0 - 9999 (in 1/10 steps)	Sensor range definition dependent
40	64	03,06	Control	Kp	[1 - 9999]	
41	65	03,06	Control	Ki	[0 - 20000]	

Modbus Index HEX	Modbus index DEC	Function	Menù category	Description	Range (DECIMAL)	Notes
42	66	03,06	Control	Min alarm value	[0 - 999,9] (unit)      0 - 9999 (in 1/10 steps)	Sensor range definition dependent
43	67	03,06	Motor	Rated motor current	[1,0 - 93,5] A      10 - 935 (in 1/10 steps)	Inverter model dependent
44	68	03,06	Control	Control mode	0=Fix speed      1=Constant value 2=MPPT      3=Fix speed 2 values 5=External speed      7=Constant value 2 set	Inverter model dependent
45	69	03,06	IN / OUT	Offset input 1	[0 - 99,9] %      0 - 999 (in 1/10 steps)	
46	70	03,06	Control	Dry run cosphy	[0 - 1,00]      0 - 100 (in 1/100 steps)	
47	71	03,06	Control	Frequency min control	[F_min_motor - F_max_motor] Hz	Frequency range definition dependent
48	72	03,06	Motor	Min motor frequency	[10 - F_max_motor] Hz	Frequency range definition dependent
49	73	03,06		Boolean word 2	Boolean words definition reference	See definitions
4A	74	03,06	Motor	Max motor frequency	[10 - F Rated_motor] Hz	Frequency range definition dependent
4B	75	03,06	Control	Operating frequency 2	[F_min_motor - F_max_motor] Hz	Frequency range definition dependent
4C	76	03,06		Boolean word 1	Boolean words definition reference	See definitions
4D	77	03,06	Control	Start delay AUX	[0 - 99] sec	
4E	78	03,06	Control	Delta stop	[0 - 999,9] (unit)      0 - 9999 (in 1/10 steps)	Sensor range definition dependent
4F	79	03,06	Control	Value set update	[1 - 99] sec	
50	80	03,06	Control	Stop delay	[1 - 99] sec	

Modbus Index HEX	Modbus index DEC	Function	Menù category	Description	Range (DECIMAL)	Notes
51	81	03,06	Control	Max alarm value	[0 - 999,9] (unit)      0 - 9999 (in 1/10 steps)	Sensor range definition dependent
52	82	03,06	Control	Address (COMBO)	[0 - 7]	
53	83	03,06	IN / OUT	Digital Input 1,2,3,4	Digital inputs definition reference	See definitions
54	84	03,06	IN / OUT	Digital Input 2/3 delay	[1 - 99] sec	
55	85	03,06	IN / OUT	Offset input 2	[0 - 99,9] %      0 - 999 (in 1/10 steps)	
56	86	03,06	IN / OUT	Offset input 3	[0 - 99,9] %      0 - 999 (in 1/10 steps)	
57	87	03,06	IN / OUT	Offset input 4	[0 - 99,9] %      0 - 999 (in 1/10 steps)	
58	88	03,06	IN / OUT	Unit	0=bar    1=psi    2=atm    3=m3/h 4=l/min   5=gpm   6=°C    7=°F    8=°K 9=m      10=cm   11=in    12=ft   13=%	
59	89	03,06	IN / OUT	Min value sensor	[0 - 999,9] (unit)      0 - 9999 (in 1/10 steps)	
5A	90	03,06	Control	Control ramp	[1,0 - 300,0] sec      10 - 3000 (in 1/10 steps)	
5B	91	03,06	Motor	V / f linear - > quadratic	[0 - 100] %	
5C	92	03,06	Control	Delta control	[0 - 999,9] (unit)      0 - 9999 (in 1/10 steps)	Sensor range definition dependent
5D	93	03,06	Control	Restart delay	[1 - 99] min	
5E	94	03,06	Control	Periodic autorun	[0 - 99] h	
5F	95	03,06	IN / OUT	AN1, AN2 function	0=Indipendent      1=Selectable 2=Difference 1-2    3=Higher value 4=Lower value	
60	96	03,06	Control	Compens.	[0 - 999,9] (unit)      0 - 9999 (in 1/10 steps)	Sensor range definition dependent

Modbus Index HEX	Modbus index DEC	Function	Menù category	Description	Range (DECIMAL)	Notes
61	97	03,06	Control	Compens. set 2	[0 - 999,9] (unit)      0 - 9999 (in 1/10 steps)	Sensor range definition dependent
62	98	03,06	Control	MPPT: voltage gap	[0,1 - 99,9] V      1 - 999 (in 1/10 steps)	Inverter model dependent
63	99	03,06	Control	MPPT: time gap	[0,1 - 3,0] sec      1 - 30 (in 1/10 steps)	Inverter model dependent
64	100	03,06	Control	MPPT: frequency gap	[0,1 - 99,9] Hz      1 - 999 (in 1/10 steps)	Inverter model dependent
65	101	03,06	Control	Open circuit voltage PV	[150 - 850] V	Inverter model dependent
66	102	03,06	Connect.	Modbus address	[1 - 247]	
67	103	03,06	Connect.	Modbus baudrate	0=1200 bps      1=2400 bps      2=4800 bps 3=9600 bps      4=14400 bps      5=19200 bps 6=38400 bps      7=57600 bps	
68	104	03,06	Connect.	Modbus data format	0=RTU N81    1=RTU N82    2=RTU E81    3=RTU O81	
69	105	03,06	Control	Alternance period	[0 - 99] h	
6A	106	03,06	Motor	Motor type	[0 - 1]      0=Threephase asynchronous 1= PM synchronous	Depends on inverter model
6B	107	03,06	Motor	Motor resistance	[[0,01 - 655,00] Ohm      1 - 65500 (in 1/100 steps)	
6C	108	03,06	Motor	Motor inductance	[0,01 - 655,00] mH      1 - 65500 (in 1/100 steps)	
6D	109	03,06	Motor	FOC dynamics	[30 - 500]	
6E	110	03,06	Motor	FOC Speed	[0 - 5]	
6F	111	03,06	IN / OUT	Flow measure	0=None; 1=Freq. proport; 2=AN2 4-20mA; 3=AN3 pulse	
70	112	03,06	IN / OUT	Rated Flow / Pulse	[1 – 9999] m3/h x 10 [1 – 9999] L/impulso x 10	
71	113	03,06	IN / OUT	Min stop flow	[0 – 9999] m3/h x 10	



Modbus Index HEX	Modbus index DEC	Function	Menù category	Description	Range (DECIMAL)	Notes
72	114	03,06	IN / OUT	F.S. Solarimeter	[0 – 9999] W/m2	
73	115	03,06	IN / OUT	Min stop irr.	[0 – 9999] W/m2	
8F	143	03,06		Password 1 (left digit)	[0 - 9]	
90	144	03,06		Password 1 (central digit)	[0 - 9]	
91	145	03,06		Password 1 (right digit)	[0 - 9]	
93	147	03,06		Password 2 (left digit)	[0 - 9]	
94	148	03,06		Password 2 (central digit)	[0 - 9]	
95	149	03,06		Password 2 (right digit)	[0 - 9]	
97	151	03	Connect.	Language	0=Italiano 1=English 2=Deutsch 3=Francais 4=Espanol 5=Polски 6=Pyckk	
98	152	03		Actual value	[0 - 999,9] (unit) 0 - 9999 (in 1/10 steps)	
99	153	03		Set value (updated)	[0 - 999,9] (unit) 0 - 9999 (in 1/10 steps)	
9A	154	03		Voltage bus (DC)	[0 - 999] V	
9B	155	03		Motor current	[0 - 99,9] A 0 - 999 (in 1/10 steps)	
9C	156	03		Frequency	[0 - 999,9] Hz 0 - 9999 (in 1/10 steps)	
9D	157	03		Power	[0 - 65500] W	
9E	158	03		Module temperat.	[0 - 100] °C	

Modbus Index HEX	Modbus index DEC	Function	Menù category	Description	Range (DECIMAL)	Notes
9F (1)	159 (1)	03		PCB temperat.	[0 - 100] °C	Inverter model dependent
9F (2)	159 (2)	03		Input current	[0 - 25,5] A      0 - 255 (in 1/10 steps)	Inverter model dependent
A0	160	03		Motor power factor	[0 - 1,00]      0 - 100 (in 1/100 steps)	
A1	161	03		Status	Status byte definition reference	See definitions
A2	162	03		Alarm	Alarm word definition reference	See definitions
A3	163	03		Alarm stored 1 (last)	[0 - 15]      (0xFFFF=none)	
A4	164	03		Alarm stored 2	[0 - 15]      (0xFFFF=none)	
A5	165	03		Alarm stored 3	[0 - 15]      (0xFFFF=none)	
A6	166	03		Alarm stored 4	[0 - 15]      (0xFFFF=none)	
A7	167	03		Alarm stored 5	[0 - 15]      (0xFFFF=none)	
A8	168	03		Alarm stored 6	[0 - 15]      (0xFFFF=none)	
A9	169	03		Alarm stored 7	[0 - 15]      (0xFFFF=none)	
AA	170	03		Alarm stored 8	[0 - 15]      (0xFFFF=none)	
AB	171	03		Electric life (high word)	[0 - 2 <sup>32</sup> ] sec	
AC	172	03		Electric life (low word)		
AD	173	03		Inverter life (high word)	[0 - 2 <sup>32</sup> ] sec	
AE	174	03		Inverter life (low word)		
AF	175	03		Motor life (high word)	[0 - 2 <sup>32</sup> ] sec	

Modbus Index HEX	Modbus index DEC	Function	Menù category	Description	Range (DECIMAL)	Notes	
B0	176	03		Motor life (low word)			
B1	177	03		Frequency range 1 (high word)	[0 - 2 <sup>32</sup> ] sec	See definitions	
B2	178	03		Frequency range 1 (low word)			
B3	179	03		Frequency range 2 (high word)	[0 - 2 <sup>32</sup> ] sec		
B4	180	03		Frequency range 2 (low word)			
B5	181	03		Frequency range 3 (high word)	[0 - 2 <sup>32</sup> ] sec		
B6	182	03		Frequency range 3 (low word)			
B7	183	03		Frequency range 4 (high word)	[0 - 2 <sup>32</sup> ] sec		
B8	184	03		Frequency range 4 (low word)			
B9	185	03		Total Flow (high word)	[0 – 99999999] m3 x10		
BA	186	03		Total Flow (low word)	[0 – 99999999] m3 x10		
BB	187	03		Flow	[0 – 9999] m3/h x10	Dependent on the scale of the meter	
BC	188	03		Irradiance	[0 – 9999] W/m2	Dependent on solarimeter Full Scale.	
BD	189	03		MAC address	2 byte (ASCII characters)		

Modbus Index HEX	Modbus index DEC	Function	Menù category	Description	Range (DECIMAL)	Notes
				(word 1, MSW)		
BE	190	03		MAC address (word 2)	2 byte (ASCII characters)	
BF	191	03		MAC address (word 3)	2 byte (ASCII characters)	
C0	192	03		MAC address (word 4)	2 byte (ASCII characters)	
C1	193	03		MAC address (word 5)	2 byte (ASCII characters)	
C2	194	03		MAC address (word 6, LSW)	2 byte (ASCII characters)	
C5	197	03		Address COMBO	[0 - 7] (0x00FF=COMBO OFF)	
C6	198	03		SW ctrl/LCD version		
C7	199	03		SW pw/INV version		
C8	200	03		Model code		
C9	201	03		Rated motor voltage max		Inverter model dependent
CA	202	03		Rated motor current max	(in 1/10 steps)	Inverter model dependent
CB	203	03		Open circuit voltage PV max		Inverter model dependent

Modbus Index HEX	Modbus index DEC	Function	Menù category	Description	Range (DECIMAL)	Notes
CF	207	03		AN1 value (analog input 1)	[0 - 32736]	
D0	208	03		AN2 value (analog input 2)	[0 - 32736]	
D1	209	03		AN3 value (analog input 3)	[0 - 32736]	
D2	210	03		AN4 value (analog input 4)	[0 - 32736]	
D3	211	03		Digital inputs status	Digital inputs status definition reference	See definitions
D4	212	03		Relays status	Relays status definition reference	See definitions

## 7. Definitions

### Boolean words definition

The boolean words (or bit\_array) are words where each bit has a precise meaning. A machine parameter can only have two values: in the case of ON / OFF value, 1 indicates ON and 0 means OFF; in the presence of the sign, 1 indicates the negative sign and 0 the positive sign; For other cases, please refer to the respective associations of strings.

#### Structure of bit\_array\_1 (Modbus Index DEC = 76):

Bit[0] = Sign min value sensor (0=positive value, 1=negative value)

Bit[1] = Motor type (0=Threephase, 1=Singlephase); Inverter model dependent

Bit[2] = Autorestart (0=OFF, 1=ON)

Bit[3] = Rotation sense (0=→, 1=←)

Bit[4] = Pump DOL 1 (0=OFF, 1=ON)

Bit[5] = Pump DOL 2 (0=OFF, 1=ON)

Bit[6] = External set enabling (0=OFF, 1=ON)

Bit[7] = Sign min alarm value (0=positive value, 1=negative value)

Bit[8] = COMBO (0=OFF, 1=ON)

Bit[9] = Alternance (0=OFF, 1=ON)

Bit[10] = Sign compens. Set 2 (0=positive value, 1=negative value)

Bit[11] = Sign compensation (0=positive value, 1=negative value)

Bit[12] = Sign set value 2 (0=positive value, 1=negative value)

Bit[13] = Sign set value (0=positive value, 1=negative value)

Bit[14] = COMBO Synchrony (0=OFF, 1=ON)

Bit[15] = PI control (0=Direct, 1=Reverse)

#### Structure of bit\_array\_2 (Modbus Index DEC = 73):

Bit[0] = BTLE connection (0=OFF, 1=ON)

The other bits of bit\_array\_2, from bit [1] to Bit [15], are not currently used.

## Digital inputs definition

The digital inputs are configured as "Normally closed" or "Normally open" through the individual bits that make up the word associated with the corresponding parameter.

### Structure of parameters Digital input 1,2,3,4 (Modbus Index DEC = 83):

For VASCO –Variable Speed Controller devices:

Bit[0] = Digital input IN1 (0=Normally closed, 1=Normally open)

Bit[1] = Digital input IN2 (0=Normally closed, 1=Normally open)

Bit[2] = Digital input IN3 (0=Normally closed, 1=Normally open); Inverter model dependent

Bit[3] = Digital input IN4 (0=Normally closed, 1=Normally open); Inverter model dependent

For MIDA devices:

Bit[2] = Digital IN1 manual reset (0=Enable, 1=Disable); Inverter model dependent

Bit[3] = Digital IN2 manual reset (0=Enable, 1=Disable); Inverter model dependent

The other parameter bits, from Bit[4] to Bit[15], are not currently used.

## Status byte definition

This byte allows to know in real time the machine operating status and at the same time lets you know immediately if you are running as "Stand-alone" or if he works in a COMBO group (the top byte of the word is currently not used).

### Association states (Modbus Index DEC = 161):

Parameter	Related strings
Status (lower nibble)	0: Inverter OFF, Motor OFF, No alarm (Status normal) 1: Inverter OFF, Motor OFF, Alarm active 2: Inverter ON, Motor OFF, Stand-by 3: Inverter ON, Motor OFF, No water 4: Inverter ON, Motor OFF, Digital input active 5: Inverter OFF, Motor ON, Ramp down (Stop command) 6: Inverter ON, Motor ON, Run 7: Inverter OFF, Motor ON, Ramp down (Alarm active) 8: Inverter ON, Motor ON, Ramp down (Stand-by) 9: Inverter ON, Motor ON, Ramp down (No water) 10: Inverter ON, Motor ON, Ramp down (Digital input active)
Status (higher nibble)	<127: Inverter stand-alone (no address) >127: Inverter COMBO (valid address)

## Alarm word definition

The alarm is a word where each bit indicates in real time the presence of a particular alarm, suitably associated to this bit.

### Association alarm strings (Modbus Index DEC = 162):

Parameter	Related strings	Associated value for identification in the alarms history
Alarm	bit0: Overcurrent motor	0
	bit1: Sensor fault	1
	bit2: Over temperature inverter	2
	bit3: Dry run cosphy	3
	bit4: Under voltage	4
	bit5: Over voltage	5
	bit6: Max value alarm	6
	bit7: Locked rotor	7
	bit8: Overload inverter	8
	bit9: IGBT trip alarm	9
	bit10: No load	10
	bit11: Address error	11
	bit12: No communication	12
	bit13: Min value alarm	13
	bit14: Keyboard fault	14
	bit15: CPU alarm	15

## Frequency range 1,2,3,4

The frequency intervals are four symmetrical intervals comprised between the maximum and the minimum motor frequency set in the advanced parameters.

Example:

Max motor frequency = 50 Hz e Min motor frequency = 30 Hz

Frequency range = (Max motor frequency - Min motor frequency) / 4 = (50 - 30) / 4 = 5 Hz

Thus:

Range (1): da 30 Hz a 35 Hz

Range (2): da 35 Hz a 40 Hz

Range (3): da 40 Hz a 45 Hz

Range (4): da 45 Hz a 50 Hz



## Digital inputs status definition

The "digital inputs status" is a word that allows to know in real time the logic state of the digital inputs of the machine, regardless of their configuration N.C. or N.O.

### Structure of Digital input status (Modbus Index DEC = 211):

Bit[0] = Digital input IN1 (0=Closed contact, 1=Open contact)

Bit[1] = Digital input IN2 (0=Closed contact, 1=Open contact)

Bit[2] = Digital input IN3 (0=Closed contact, 1=Open contact); Inverter model dependent

Bit[3] = Digital input IN4 (0=Closed contact, 1=Open contact); Inverter model dependent

The other bits of the word, from bit [4] to Bit [15], are red as 0.

## Relays status definition

The relays status is a word that allows to know in real time the logic state of the digital outputs (relays).

### Structure of Relays status (Modbus Index DEC = 212):

Bit[0] = Relay 1 "STATUS" (0=Disabled, 1=Active)

Bit[1] = Relay 2 "ALARM" (0=Disabled, 1=Active)

Bit[2] = Relay 3 "DOL\_1" (0=Disabled, 1=Active); Inverter model dependent

Bit[3] = Relay 4 "DOL\_2" (0=Disabled, 1=Active); Inverter model dependent

The other bits of the word, from bit [4] to Bit [15], are red as 0.

## 8. Function codes

Only two function codes are supported:

- **0x03 Read Holding Registers – READ COMMAND**

Example: Read the Actual value

### QUERY

Slave Address	0x01	Device address as set on connectivity parameters menu
Function	0x03	Read Holding Register
Starting Address High	0x00	
Starting Address Low	0x97	Modbus index 0x98  WARNING: The Modbus indexes are addressed starting from zero thus address 0x98 has to be addressed as 0x97
No. of Points High	0x00	
No. of Points Low	0x01	It is possible to read only one holding register
Error Check CRC-High	0x35	
Error Check CRC-LOW	0xE6	CRC-Checksum

### RESPONSE

Slave Address	0x01	
Function	0x03	
Byte Count	0x02	
Data High	0x00	
Data Low	0x23	23 HEX means 35 DEC and thus actual value is 3.5 bar
Error Check CRC-High	0xF9	
Error Check CRC-LOW	0x9D	CRC-Checksum

- **0x06 Write Single Register – WRITE COMMAND**

Example: Set the “set value” to 4.5 bar

**QUERY**

Slave Address	0x01	Device address as set on connectivity parameters menu.
Function	0x06	Write Single Register
Register Address High	0x00	
Register Address Low	0x33	Modbus index 0x34  WARNING: The Modbus indexes are addressed starting from zero thus address 0x34 has to be addressed as 0x33
Preset Data High	0x00	
Preset Data Low	0x2D	2D HEX means 45 DEC and thus set the “set value” to 4.5 bar
Error Check CRC-High	0xB9	
Error Check CRC-LOW	0xD8	CRC-Checksum

**RESPONSE**

Slave Address	0x01	
Function	0x06	
Register Address High	0x00	
Register Address Low	0x33	
Preset Data High	0x00	
Preset Data Low	0x2D	2D HEX means 45 DEC and thus the “set value” is 4.5 bar
Error Check CRC-High	0xB9	
Error Check CRC-LOW	0xD8	CRC-Checksum

