



> we move it faster >

NERA solar submersible pumps

Installation and Operating Manual



Index

1. Introduction to the NERA solar submersible pumps range	3
2. Safety Instructions	3
3. Stocking conditions	3
4. Packing content.....	4
5. General technical features	4
6. Pump installation	4
6.1 Installing pump in the well.....	5
6.2 Installing the pump in a solar pumping system	5
6.3 Pump cable.....	6
6.4 Water level sensing.....	7
7. Troubleshooting.....	8

1. Introduction to the NERA solar submersible pumps range

NERA are a 4" submersible solar pumps for clean water composed by:

- three phase permanent magnet motor with wet rotor and canned type resin filled stator.
- Stator on-board inverter.
- Multi stage pump entirely made of AISI 304 stainless steel (centrifugal models)
- Helical rotor pump (helical rotor model)

NERA pumps are fed by DC voltage with wide margins of operating voltage (70-190 VDC).



In the application with photovoltaic panels, the MPPT algorithm maximizes, for various conditions of irradiation and temperature, the electric power obtained from the panels thus the amount of water extracted.

Pump speed is adjusted in relation to solar irradiation. When solar irradiation increases, pump will run faster thus pumping more water. When solar irradiation decreases (clouds moving or different hours of the day) pump will reduce its frequency and so delivery but it continues pumping till solar irradiation reaches the minimum value necessary for working.

2. Safety Instructions

The manufacturer strongly suggests to reading carefully this operation manual before using and installing its products

Any operation (installation, maintenance and repair) must be carried out by trained, skilled and qualified personnel. Failure to observe and follow the instruction of this manual may result fatal in dangerous electric shock.

 	<p>The unit must be connected to the power supply by a switch granting the complete visual disconnection (separation) from the line before any operation. Disconnect the unit from the power supply before any operation. NERA and pump system must be grounded properly before any operation. Do not start the pump for any reason if not completely immersed in water.</p>
--	--

Avoid any shock or serious impact during transportation.

Damages due to transportation, incorrect installation, or improper use of the device will null and void the warranty.

The manufacturer cannot be held responsible for any damage to people and/or property due to improper use of its products.

3. Stocking conditions

Store the product on its packaging in a dry and well ventilated environment within a temperature range from -20 ° C to 50 ° C.

If the pump remains in stock for more than a year is recommended to disassemble the rotating parts and test their functionality. It 'also need to power the electric pump (without running the motor) to allow charging of electrolytic capacitors of the inverter module.

If the pump has already been put into operation and is then placed in storage, the minimum storage temperature is 4 ° C. Alternatively you need to add anti-freeze fluid.

4. Packing content

Packing includes:

- NERA submersible pump with 2,5 meters flat cable length.
- Cable junction kit.
- Operating Manual.



Check the packing immediately upon delivery and check for damage and/or missing parts; in either cases immediately notify the supplier.

5. General technical features

NERA PUMP

Max. temperature of pumped liquid	35 °C (92 °F)
Min. speed of water flow on motor case	0.2 m/s
Characteristics of pumped liquid	clean, non-corrosive, non-explosive, free of particles and fibers, with a maximum sand content of 50 g/m ³
Grade of protection	IP68
Used Materials	Pump and motor body in AISI 304
Cable	Flat cable ACS – KTM - WRAS approved
Supply Voltage	70 – 190 VDC
Max input power	800 W

CERTIFICATIONS

CE

6. Pump installation



Entire installation procedure must be performed verifying that pump is not connected to the power supply.

Pump can be installed both vertically and horizontally, but the outlet should never be below the horizontal line. Minimum head of 10% than max pump head must be granted.

If the pump is not installed in a well, to grant a proper cooling, a cooling sleeve must be used; doing so the minimum speed of the pumped liquid has to be granted.

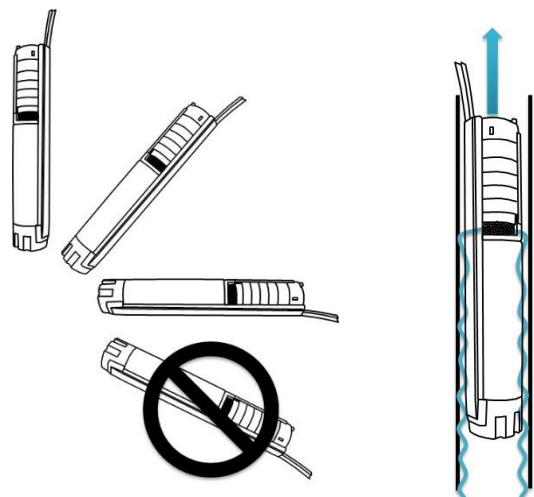

6.1 Installing pump in the well

To reduce noise transmission it is advised to use plastic pipes.

The pump must always be secured in the well through a special rope attached to loop on the pump head.

It is recommended not to drop the pump in the well by using the electric cable, its integrity must be preserved in all operations. In this regard it is recommended to fix the cable on cable support or on the pipe.

During operation the pump suction must always remains at least 1.5 meters below the dynamic water level.

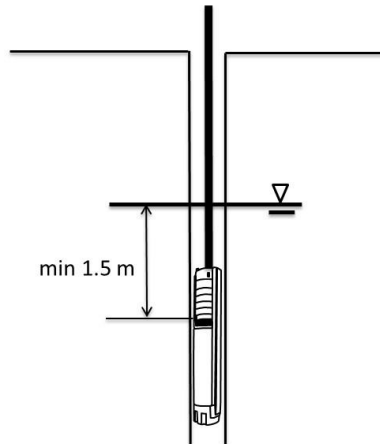

Do not drop the pump in the well by using the electric cable
Make sure about the electric cable integrity during all the operations.
Ensure the pump in the well with a stainless steel rope to be fixed to the hole in the pump head

6.2 Installing the pump in a solar pumping system

All protections of overload, overvoltage and dry running protection are integrated into the on board inverter.

It is recommended anyway to install the DC switch to start and stop the pump and to ensure a proper disconnection between the pump and panels during maintenance.

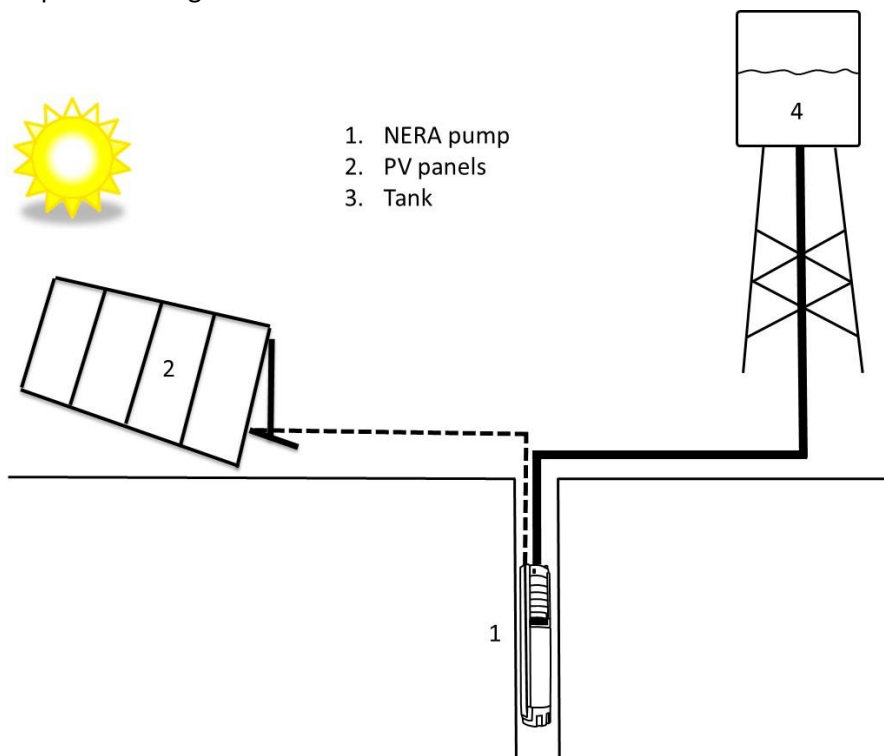

6.3 Pump cable

NERA pumps are equipped, in their standard configuration, with 2,5 meter flat cable length.

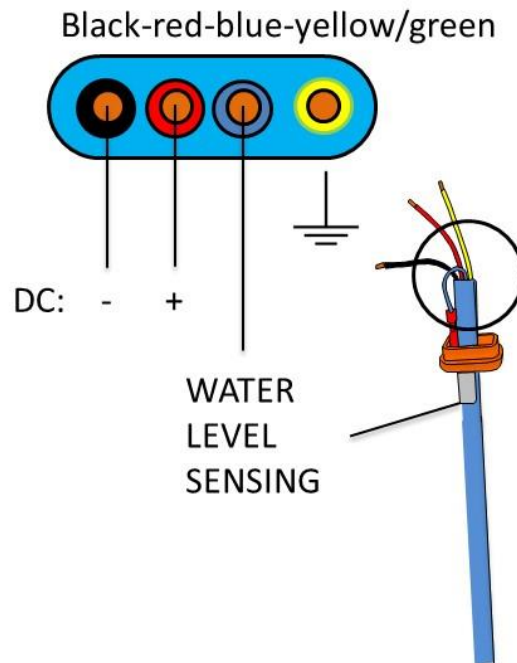

**It is necessary to respect polarity !
Not respecting the polarity causes irreparable pump failure**

If the distance between the pump and the power supply is longer than the supplied cable it is necessary to make a junction performed by the special kit supplied as standard.
The cable section for additional power conductors must be calculated considering the maximum allowed power loss.

$$S = \frac{2 \times \rho \times L \times P1 \times 100}{V^2 \times \Delta P_{[\%]}}$$

- S: wire section [mm²]
- ρ : specific resistance = 0,018 [Ω mm²/m]
- L: cable length [m]
- P1: pump electrical power [W].
- V: voltage at maximum power.
- ΔP : allowed power loss [%]. It is recommended not to exceed 3%.



To make the junction is necessary to follow carefully the instructions inside the kit.

At the time of joining and electrical connection is essential to maintain the correspondence between the cables.

After cable joining and placed the pump in the well you must perform, before connecting to power supply, a test of insulation: join together the two power cables and, applying a voltage of 500V, an insulation resistance from the ground higher than 100 Mohm must be verified. Join together the two signal cables and, applying a voltage of 500V, an insulation resistance from the ground higher than 100 Mohm must be verified.

6.4 Water level sensing

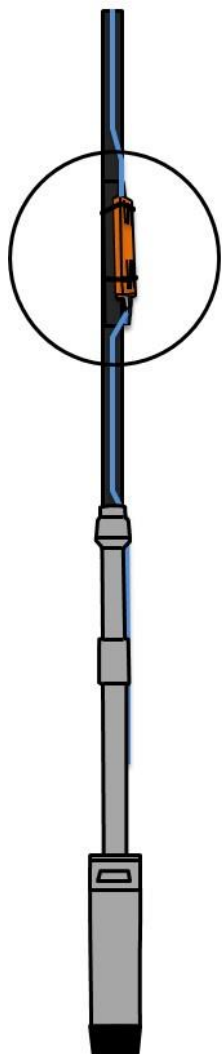

WATER LEVEL SENSOR

Water level sensing is based on variation of measured impedance. Keep it clean and not in direct contact with pipes in order to grant its function.

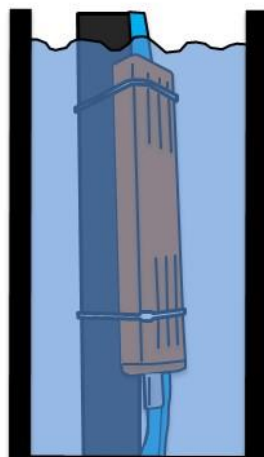
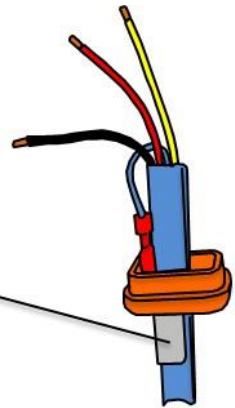

WATER

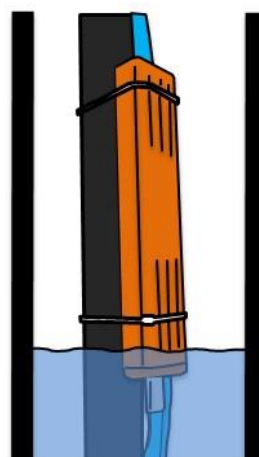

WATER

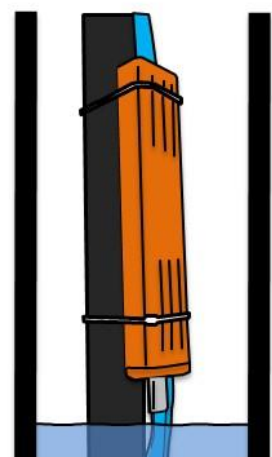

NO WATER

7. Troubleshooting

If the pump, after the installation and power supply connection, doesn't provide any water please verify:

- correct wiring.
- voltage conditions (70 – 190 VDC).
- enough power available (solar irradiance).
- water presence: if pump during operation runs dry, an alarm occurs and pump will stop. Every 5 minutes pump will attempt to restart the operation after 5 minutes.

DECLARATION OF CONFORMITY

In according with:

Machine Directive 2006/42/EC

EMC Directive 2004/108/CE

Low Voltage Directive 2006/95/EC

We Nastec srl, Via della Tecnica, 8, 36024, Mossano, Vicenza, Italy, declare that **NERA solar pumps** conform to the following regulations:

EN 55011 Class A

EN 60335-1, EN60335-2-41

Ing. Marco Nassuato
Operation Manager



